



## Controller 704

### Технические характеристики

По вопросам продаж и поддержки обращайтесь:

Архангельск (8182)63-90-72	Калининград (4012)72-03-81	Нижний Новгород (831)429-08-12	Смоленск (4812)29-41-54
Астана +7(7172)727-132	Калуга (4842)92-23-67	Новокузнецк (3843)20-46-81	Сочи (862)225-72-31
Белгород (4722)40-23-64	Кемерово (3842)65-04-62	Новосибирск (383)227-86-73	Ставрополь (8652)20-65-13
Брянск (4832)59-03-52	Киров (8332)68-02-04	Орел (4862)44-53-42	Тверь (4822)63-31-35
Владивосток (423)249-28-31	Краснодар (861)203-40-90	Оренбург (3532)37-68-04	Томск (3822)98-41-53
Волгоград (844)278-03-48	Красноярск (391)204-63-61	Пенза (8412)22-31-16	Тула (4872)74-02-29
Вологда (8172)26-41-59	Курск (4712)77-13-04	Пермь (342)205-81-47	Тюмень (3452)66-21-18
Воронеж (473)204-51-73	Липецк (4742)52-20-81	Ростов-на-Дону (863)308-18-15	Ульяновск (8422)24-23-59
Екатеринбург (343)384-55-89	Магнитогорск (3519)55-03-13	Рязань (4912)46-61-64	Уфа (347)229-48-12
Иваново (4932)77-34-06	Москва (495)268-04-70	Самара (846)206-03-16	Челябинск (351)202-03-61
Ижевск (3412)26-03-58	Мурманск (8152)59-64-93	Санкт-Петербург (812)309-46-40	Череповец (8202)49-02-64
Казань (843)206-01-48	Набережные Челны (8552)20-53-41	Саратов (845)249-38-78	Ярославль (4852)69-52-93

сайт: [www.mjk.nt-rt.ru](http://www.mjk.nt-rt.ru) || эл. почта: [mkj@nt-rt.ru](mailto:mkj@nt-rt.ru)



General



The MJK 704 Level / Pump Controller is a microprocessor based unit used with either an ultrasonic sensor or a hydrostatic transmitter.

The 704 Controller is designed to maintain level in tanks and control up to four pumps. Functions for control, alarm, indication and flow calculation are selectable.

The 704 Controller can be configured to control speed of, and alternate, variable speed drives.

Features

- Ultrasonic sensor, hydrostatic pressure transmitter or 4 - 20 mA input.
- Standard measurement ranges from 0 - 10 ft. up to 0 - 100 ft. in liquids / sludge.
- Measures and indicates level, numbers of starts, pump run time, calculates capacity and output for each pump and total capacity for the whole pumping station.
- English or metric measurement units
- Direct indication of elevation for use in flood plains or areas where USGS elevations are required.
- Text display for programming and reading of measurement values with all indications in plain language (English, French, and Spanish).
- 4 relays for control and alarms.
- Lead/lag pump alternation.

Operation

- Menu system with easy and logical functions.
- Start-up menu for first time operation, so that all parameters are correctly entered.
- The pump controller is operated by clearly marked keys.
- Simplified field installation due to user friendly logical functions.
- Pumps can be manually controlled on or off, directly from the pump controller.

Functions

- Alternation of two to four pumps (first in first out).
- Two by two alternation of small and larger pumps.
- Alternation in sequences.
- Alternation by running hours.
- Choice of numbers of synchronous pumps in operation.
- A function which allows the deep pump down of a well or pumping station.
- Automatic start of back-up pump.
- Pumps can be taken out of service from the keypad.
- Manual start/stop of pumps.
- Free choice of delay of start for each pump, limiting current surge and water hammering.
- Alarms for level and system error.
- Delays on alarm outputs.

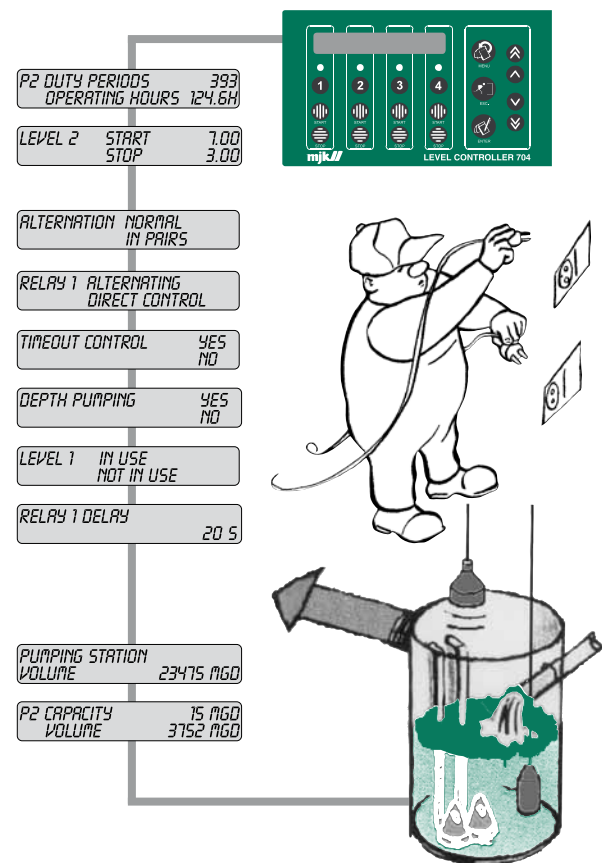

Flow calculation

The pump controller calculates both output and flow capacity of the individual pump, along with the total flow capacity of the pumping station.

The calculation model is independent of the actual pump characteristics and does not require pump data programming. Accuracy of up to 1% of flow can be calculated.



704U Level / Pump Controller System Package

704 Level / Pump Controller and Shuttle® Ultrasonic Sensor with standard sensor bracket.



The MJK 704 Level Controller System Package 1 is supplied with the Shuttle® Ultrasonic Sensor with 0 - 30 ft. measuring range. The Shuttle® sensor provides non-contact level measurement system, which is ideal for use in most water and wastewater level applications.

Features

- Non-contact measuring method; no moving parts, no maintenance.
- Only 3 ° beam angle. The narrow beam angle provides high signal intensity and minimum sensitivity to foam and sludge on the surface.
- Survives immersion down to 30 ft.
- Logic noise protection system ignores electrical disturbances, turbulence and interference from mixers.

Connections

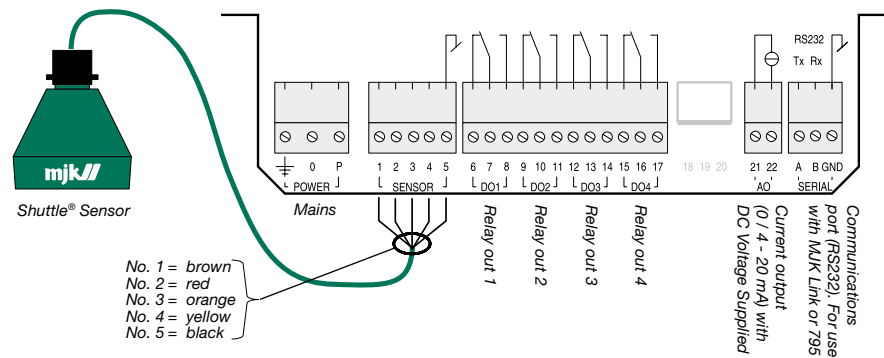

Specifications

Shuttle® Sensor	
Measuring range:	0 - 30 ft.
Frequency:	30 kHz
Beam angle:	3 °
Temperature range:	- 5 to + 150 °F
Accuracy	Better than ± 0.4 "
Deadband:	30 "
Materials:	Polypropylene (green) / POM (black)
Cable:	Shielded, oil resistant PVC insulation, length 39 ft. (Max. 300 ft. with 690010 cable.)
Enclosure:	NEMA 6P, waterproof, withstands submersion, max. 30 ft.
CE-approvals:	EN50081-1, EN50082-1

Dimensions

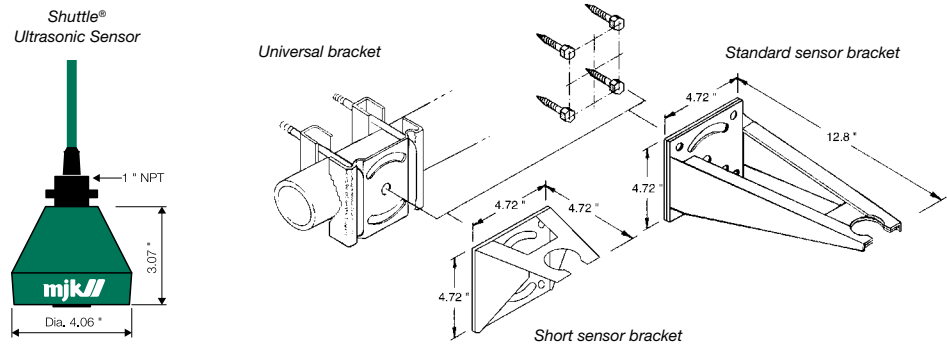



704P Level / Pump Controller System Package

704 Level / Pump Controller and model 2100 Pressure Transmitter



The 704 Level / Pump Controller System Package 2 is supplied with the model 2100/3400 Level Transmitter for user selected measuring ranges of up to 30 ft. The 704 Level / Pump Controller is ideal for applications where surface conditions make it difficult for ultrasonic measurements or where access for surface measurements is difficult.

Features

- Sturdy 2100 pressure transmitter with 316L stainless steel diaphragm, or 3400 with ceramic pressure diaphragm.
- The transmitter has a steel reinforced cable which can withstand a tensile stress up to 2,000 lbs.
- The transmitter has a polyethylene pressure equalizing tube in the cable.
- The transmitter housing is designed to prevent clogging of the pressure sensor.

Connections

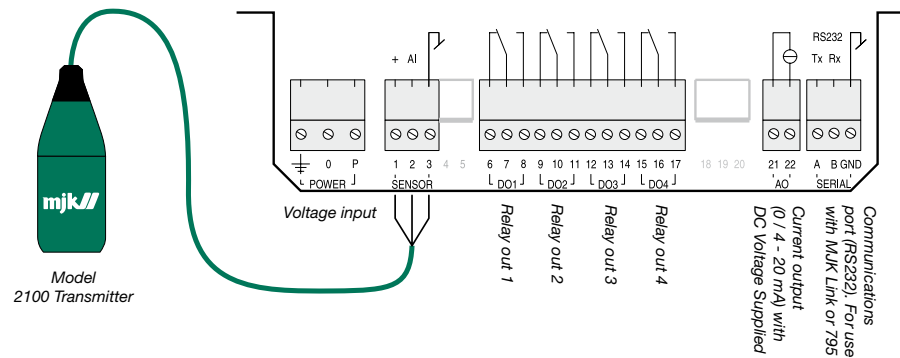

Specifications

Model 2100 Transmitter

Measuring ranges:	0 - 10 ft. relative pressure, 0 - 30 ft. relative pressure (Other ranges available.)
Output signal:	4 - 20 mA, 2-wire
Accuracy:	Better than $\pm 1\%$
Temperature range:	+ 5 to + 150 °F
Materials:	Polypropylene (green) / POM (black), membrane from 316L stainless steel.
Cable:	2 x AWG 20, shielded, oil resistant PVC insulation. Length 39 ft. (can be extended)
Enclosure:	NEMA 6P, submersible up to 100 ft.
CE-approvals:	EN50081-1, EN50082-1

Model 3400 Transmitter

Measuring Ranges:	0-10 ft. or 0-30 ft. (Other ranges available)
Signal Output:	4-20 mA
Accuracy:	+/-0.1%FS in most applications
Temperature Range:	+ 15 to 160 °F
Materials:	PPS, POM, PUR (cable) and Ceramic 99.9% Al2O3 Diaphragm, Viton Packing (other materials available)
Enclosure:	NEMA 6P. Submersible to the measuring range.
Approvals:	UL® Class 1 Division 1 Group A-D (pending) / ATEX Ex ia IIC T6 Note: all hazardous installations require the 3400 to have loop isolation or fault barriers. CE EN50081-1, EN50082-1

Dimensions

Mounting Bracket

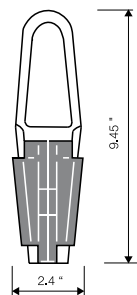

Model 2100 Transmitter



Model 3400 Transmitter





Communication

When the 704 is connected to a PC via MJK Link via the MJK 795 the following functions can be adjusted, executed and read:

- Configuration.
- Logging of levels.

- Start and stop levels for pumps and alarms.
- Start and stop (blocking of pumps).
- Counters and time meters.
- Calculation of volume and throughput of one pump and pumping station.

Remote control and monitoring with MJK Data Transmitter 795



When the 704 is connected to an MJK Data Transmitter 795 an advanced monitoring system for remote control and monitoring becomes available.

The Data Transmitter is an advanced data logger with interface and modem that automatically communicates with the pump controller. The data logger can log in intervals from 30 seconds to 30 minutes (24 h to 100 days).

The 704/795 combination has five analog and twenty digital inputs / outputs available, more than one hundred counters and hour counters, alarm reporting and logical PLC functions.

The system can control pumps, measure and record storm flows, power failures and external functions. Data Transmitter 795 can communicate via public telephone network and cellular networks / datanet, including

owned lines and closed radio systems. Data can be exchanged between MJK Link™ and MJK Web-Link™ or other 795 Data Transmitters.

MJK-Link™ and MJK-Monitor™ is software developed by MJK to be used for SCADA systems, and for configuring the 704 pump controller.

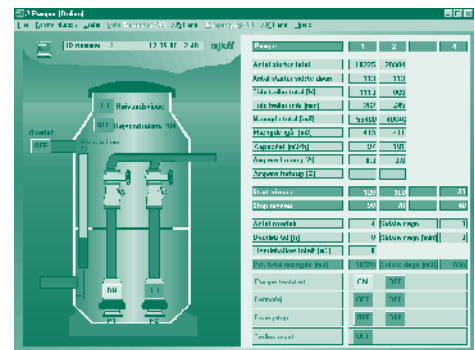

From MJK-Link™: Pump station with 2 pumps and storm flow.

Specifications

704 Level / Pump Controller

Measuring range:	Determined by sensor (see below)
Voltage supply:	110-120 V AC, power consumption max. 10 W. (24 V AC and 230 V AC options available.)
Temperature range:	(-20) - 0 to + 150 °F
Input signal:	From Ultrasonic Sensor, Pressure Transmitter or 4 - 20 mA input signal
Accuracy:	≤ ± .25 % of adjusted range
Outputs:	Analog: 0 - 20 / 4 - 20 mA, max. 500 Ω loop resistance Digital: 4 x relays with voltage free switching contacts Max. load: 250 V, 4 A resistive load, max. 100 W inductive load. Data: RS232 serial port. Uses a Comli driver, consult factory for information.
Dimensions:	Height 7.28", width 9.45", depth 4.53"
Materials & enclosure:	Polystyrol with transparent lid, NEMA 4X
Approvals:	UL-cUL listed, file # 194021 UL 508/c22: 2 No. 142-M1987

See MJK data sheets 6.2, 6.22, and 6.29 for MJK 795, MJK 702 and MJK Link products for data communication options for the MJK 704.



Dimensions

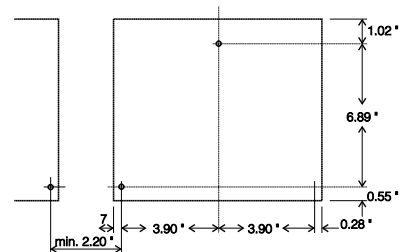
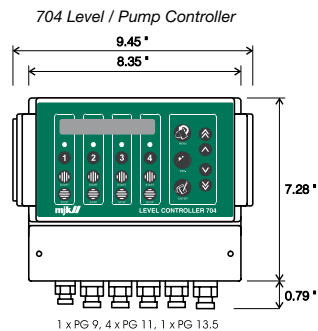

**Order numbers,  
standard**
*704 Controller Only w/4-20mA sensor input*

209030	704P Level Controller, 4-20mA input w/o sensor, Standard, 115VAC
209031	704P Level Controller, 4-20mA input w/o sensor, Galvanic Isolation, 115VAC
209032	704P Level Controller, 4-20mA input, w/o sensor, Galvanic Isolated, 24VDC

*704P Controller with 2100 Hydrostatic Level Sensor*

209035	704P Pressure Level Sensor System Package, w/Series 2100 Transmitter 0-10ft., 39 ft. cable Standard, 115 VAC
209036	704P Pressure Level Sensor System Package, w/Series 2100 Transmitter, 0-10ft., 39ft. Cable, Galvanic, 115 VAC
209040	704P Pressure Level Sensor System Package, w/Series 2100 Transmitter 0-30ft., 39ft. Cable Standard, 115 VAC
209041	704P Pressure Level Sensor System Package, w/Series 2100 Transmitter, 0-30ft., 39ft. Cable, Galvanic, 115 VAC
209042	704P Pressure Level Sensor System Package, w/Series 2100 Transmitter, 0-10ft., 39ft. Cable, Galvanic, 24VDC
209043	704P Pressure Level Sensor System Package, w/Series 2100 Transmitter, 0-30ft., 39ft. Cable, Galvanic, 24VDC

*704P Controller with 3400 Hydrostatic Level Sensor*

209044	704P Pressure Level Sensor System Package w/ Series 3400 transmitter, 0-10 ft., 39ft. cable UL Class 1 Div.1 a-d pending, 115 VAC
209045	704P Pressure Level Sensor System Package w/ Series 3400 transmitter, 0-30 ft., 39ft. cable UL Class 1 Div.1 a-d pending, 115 VAC
209046	704P Pressure Level Sensor System Package w/ Series 3400 transmitter, 0-10 ft., 39ft. cable UL Class 1 Div.1 a-d pending, Galvanic Separation, 24VDC
209047	704P Pressure Level Sensor System Package w/ Series 3400 transmitter, 0-30 ft., 39ft. cable UL Class 1 Div.1 a-d pending, Galvanic Separation, 24VDC
202920	Price adder for special cable range
202925	Price adder for special measuring range
691014	Heavy duty PUR cable price per foot over the standard sensor cable length
100060	Special Order Rush Delivery = 7-10 days

*704U Controller without ultrasonic sensor*

209050	704U level Controller for use with Ultrasonic Sensor, Standard 115VAC
209051	704U level Controller for use with Ultrasonic Sensor, Galvanic, Isolation, 115VAC

**Order numbers,  
special**
*704U Controller with ultrasonic sensor*

209060	704U Ultrasonic Sensor System Package, 0-30 ft, with 200570 30kHz sensor, 3-degree beam, 39 ft cable, Standard 115VAC
209061	704U Ultrasonic Sensor System Package, 0-30 ft, with 200570 30kHz sensor, 3-degree beam, 39 ft cable Galvanic Isolation. 115VAC
209062	704U Ultrasonic Sensor System Package, with 200630 sensor, 0-30 ft, 30kHz, Galvanic Isolation. FM Class 1 Div 1 a-d pending, 24VDC
209063	704U Ultrasonic Sensor System Package, 0-30 ft, with 200640 40kHz sensor, 7 degree beam, FM Class 1 Div 1 a-d pending, Galvanic Isolation. 24VDC

*Accessories*

200105	Panel Mounting Kit for 704 and 713
200115	Sun/Rain Shield Kit for Shuttle/713/704 series
200219	Bracket for ultrasonic sensor, short
200220	Bracket for ultrasonic sensor, standard
200205	Universal Bracket
209100	Power Supply 515, 24VDC/0.1A 115VAC
200590	Connection box for ultrasonic sensor cable
690010-FT	Cable for Ultrasonic Sensor 7005
202922	Connection Box for Submersible Level Transmitter Cable
200126	Display Insert 531, 4-20mA loop powered, For Connection Box 202922
200117	Sun/Rain Roof for Field Display/Connection Box 202922
560915	Mounting Bracket for 2100, 3100, 3400, heavy duty cabled (>200ft) 1100 and 1400.
560916	Cable Bracket for 7030 Float Switches and standard cable for 1100 series.

Special cable lengths and sensor ranges are available to meet almost any application need. Please consult your MJK Representative.



По вопросам продаж и поддержки обращайтесь:

Архангельск (8182)63-90-72	Калининград (4012)72-03-81	Нижний Новгород (831)429-08-12	Смоленск (4812)29-41-54
Астана +7(7172)727-132	Калуга (4842)92-23-67	Новокузнецк (3843)20-46-81	Сочи (862)225-72-31
Белгород (4722)40-23-64	Кемерово (3842)65-04-62	Новосибирск (383)227-86-73	Ставрополь (8652)20-65-13
Брянск (4832)59-03-52	Киров (8332)68-02-04	Орел (4862)44-53-42	Тверь (4822)63-31-35
Владивосток (423)249-28-31	Краснодар (861)203-40-90	Оренбург (3532)37-68-04	Томск (3822)98-41-53
Волгоград (844)278-03-48	Красноярск (391)204-63-61	Пенза (8412)22-31-16	Тула (4872)74-02-29
Вологда (8172)26-41-59	Курск (4712)77-13-04	Пермь (342)205-81-47	Тюмень (3452)66-21-18
Воронеж (473)204-51-73	Липецк (4742)52-20-81	Ростов-на-Дону (863)308-18-15	Ульяновск (8422)24-23-59
Екатеринбург (343)384-55-89	Магнитогорск (3519)55-03-13	Рязань (4912)46-61-64	Уфа (347)229-48-12
Иваново (4932)77-34-06	Москва (495)268-04-70	Самара (846)206-03-16	Челябинск (351)202-03-61
Ижевск (3412)26-03-58	Мурманск (8152)59-64-93	Санкт-Петербург (812)309-46-40	Череповец (8202)49-02-64
Казань (843)206-01-48	Набережные Челны (8552)20-53-41	Саратов (845)249-38-78	Ярославль (4852)69-52-93

сайт: [www.mjk.nt-rt.ru](http://www.mjk.nt-rt.ru) || эл. почта: [mkj@nt-rt.ru](mailto:mkj@nt-rt.ru)